

Inside

From the Executive Director	2
AIC News	3
FAIC News	4
Allied Organizations	5
New Publications	6
People	7
New Materials and Research	7
Worth Noting	7
ANAGPIC	13
Specialty Groups	13
Courses, Conferences, and Seminars	14
Positions, Internships, and Fellowships	17

AIC's 38th Annual Meeting

See you May 11-14 in
Milwaukee at...

*The Conservation Continuum:
Examining the Past/
Envisioning the Future*

More information and online
registration are available at
[www.conservation-us.org/
meetings](http://www.conservation-us.org/meetings)

Look for a full report on the
meeting in the July issue of
AIC News!

From Collaboration to Aggregation: Internet Resources and the Future of Conservation

By *Ariel O'Connor*

Faced with the treatment of a three-foot tall ceramic figure, I battled with the task to reconstruct multiple losses on the sculpture without a comparable reference. Catalog information described the figure as Chinese, from the Ming dynasty, but listed nothing about its provenance or history. I turned to traditional sources: books, published articles, and colleagues to help identify the object. None of them had information on similar figures.

In the old days, this would have posed a significant hurdle. Today, however, it is second nature for the vast majority of conservators to turn to the Internet for help. I tried Google and uncovered a similar figure owned by a museum in Macau, China. Further online research pinpointed its origin to the remote city of Shiwan. Flickr and other image-sharing websites provided photographs of similar sculptures in situ on southern Chinese temples.

The methodology used in researching this object caused me to wonder: how have developments in Internet resources impacted the field of conservation? How do conservators use the Web? Do we use it efficiently? How might that change in the future?

The Past

Traditionally, conservators acquired large and cumbersome personal libraries. When these weren't enough, collaboration and collegial input was sought. Many active conservators remember when options were limited to letters, telephone calls and interaction at meetings. The advent of email helped speed the process, but collaboration was limited to coworkers, friends, and acquaintances and the body of conservation knowledge remained in printed form.

Walter Henry's innovative thinking in 1987 launched the Conservation DistList, part of Conservation OnLine (CoOL). This tool was one of the first forums to connect people from multiple disciplines and locations. FAIC recently took over responsibility for the DistList and it continues to be one of the primary online resources used by conservators.

The Present

We are currently in the midst of an information revolution. Many of us now consider Google a starting point for research; bibliographic databases for downloadable journals and articles are also heavily relied upon. Continuing education has become easier and more prevalent with the introduction of interactive webinars and e-learning resources. Through online training provided by FAIC and its specialty groups, more and more conservators continue their education electronically.

This easy access to information is one of the major developments that have so

continued on page 8

AIC NEWS

AIC News (ISSN 1060-3247) is published bi-monthly by the American Institute for Conservation of Historic & Artistic Works, 1156 15th Street, NW, Ste. 320, Washington, D.C. 20005, (202) 452-9545; Fax: (202) 452-9328; info@conservation-us.org
www.conservation-us.org

Periodicals postage paid at Washington, D.C.
Postmaster: Send address changes to:
AIC News
1156 15th Street, NW, Suite 320
Washington, D.C. 20005

AIC News is mailed to members for \$18 per year as a portion of annual membership dues. Opinions expressed in AIC News are those of the contributors and not official statements of AIC. Responsibility for the materials/methods described herein rests solely with the contributors.

Deadline for July editorial submissions (brodgers@conservation-us.org): June 1, 2010.
We reserve the right to edit for brevity and clarity.

ADVERTISING

AIC accepts position-available ads only from equal opportunity employers. All position ads must conform to the standards for equal opportunity employment. The cost of Internships and Fellowships, Positions Available, and Classified Ads is: \$1.05 per word for members and \$2.15 per word for nonmembers; the minimum charge is \$75. The cost of display ads is: 1/6 page \$215; 1/3 page \$360; 1/2 page \$445; 2/3 page \$570; full page \$695.

Deadlines for advertising copy are: February 10, April 10, June 10, August 10, October 10, and December 10. All ads should be submitted to Ruth Seyler at rseyler@conservation-us.org.

AIC NEWS STAFF

Lisa Goldberg, Editor
James Martin, Editor, New Materials & Research
Eryl P. Wentworth, Managing Editor
Brett Rodgers, Production Editor
Ruth Seyler, Marketing Director
Eric Pourchot, Institutional Advancement Director

© Copyright 2010. AIC News cannot be reproduced in its entirety without permission from AIC. Individual articles may be reproduced if permission has been granted by the owner of copyright and proper citation attributed. The paper used in this publication meets the minimum requirements of American National Standard for Information Sciences—Permanence of Paper for Publications and Documents in Libraries and Archives, ANSI/NISO Z39.48-1992.

From the Executive Director



FAIC has recently received several awards that allow it and AIC to further conservation efforts in two parts of the world where such assistance is crucial to the success of current preservation efforts. Although these grant awards are highlighted in the FAIC column, I'd also like to highlight here two that are particularly significant here.

Seeking a way to show united support for cultural recovery efforts in Haiti, the National Endowment for the Humanities (NEH), National Endowment for the Arts (NEA), Institute for Museum and Library Services (IMLS), and President's Committee for the Arts and the Humanities (PCAH) all decided to support FAIC in assisting AIC-CERT deployment to Haiti. NEH, NEA, and IMLS have each committed \$30,000 and PCAH an additional \$10,000. The award documentation is in progress. Over the past few months, we have been working closely with the U.S. Committee of the Blue Shield to coordinate efforts with other responding organizations and with the Haitian government. Look for more information on the AIC website.

Reflecting a longstanding commitment of The Andrew W. Mellon Foundation to develop the field of photograph conservation, the Foundation is supporting the establishment of a photographic conservation laboratory at the State Hermitage Museum in St. Petersburg, Russia. We sincerely thank the Mellon Foundation for their recent award of \$3.46 million to FAIC to manage and help guide this important initiative. This four-year initiative includes training two Russian conservators in photograph conservation and will serve as a model for best practices in photograph conservation, cataloging, and digital imaging. These resources will be housed on CoOL in both Russian and English. Please see the FAIC section of the newsletter for more information about this significant grant.

On March 19, Angelica Rudenstine retired from The Andrew W. Mellon Foundation, having led the Museums and Art Conservation program over the past 17 years. A reception was held in her honor on March 9 at the Institute of Fine Arts in New York. While a number of conservators and conservation scientists spoke movingly of Mrs. Rudenstine's many contributions, they could not fully encompass in the time available the depth and breadth of the impact of her work on the field of conservation. In this short column, I can only express the gratitude of AIC and FAIC for Mrs. Rudenstine's insightful leadership and support while at the Mellon Foundation. We are honored to be able to work with her in her role of consultant to the Mellon Foundation on the Hermitage Museum initiative.

Sadly, March also marked the end of Anne-Imelda Radice's tenure leading the Institute of Museum and Library Services (IMLS). Dr. Radice's commitment to conservation and preservation began with her experience as a "mud angel" in Florence and resulted in major initiatives created at IMLS to promote and support conservation. The *Connecting to Collections* initiative and the Bookshelf program (which distributed 1,000 copies of *The AIC Guide to Digital Photography and Conservation Documentation*), in addition to new and ongoing IMLS grant programs, have been invaluable in disseminating information about conservation and increasing visibility of the field to those who use conservation services.

I look forward to seeing many of you in Milwaukee. It promises to be an excellent meeting—and a wonderful opportunity for me to share with you more news of AIC and FAIC activities and to learn more about what issues are important to you!

—Eryl P. Wentworth
Executive Director

AIC News

Looking Closer

AIC is serving as a professional organizational partner for a proposed online exhibit with the working title of *Looking Closer: An Online Exhibit of 100 Conservation Stories*. The lead organization will be the Center of Interdisciplinary Science for Art, Architecture and Archaeology at University of California San Diego. As planned, *Looking Closer* will be a richly interactive online and museum-style exhibit that will provide an intimate view of a diverse range of scientific and engineering technologies and methodologies used for art, archaeology, and architecture conservation. The exhibit will consist of 100 case studies, rich with multimedia, from a diverse range of conservation sub-disciplines. The goal is to increase knowledge of art conservation science among non-specialists and to improve attitudes toward the sciences among students and the general public.

AIC will provide advice to core team members on the choice of topics, presentation, and framing of the exhibit for the general public. We are seeking ideas from our members for case studies and will, potentially, ask for contributions of text, images, and video that would be of interest to visitors and teachers. Once funding has been secured for the project, AIC will create a peer-review task force to review draft stories and to ensure professional standards are met.

E-newsletter

AIC is proud to announce that we will begin offering an electronic version of *AIC News* beginning with the July 2010 issue. The electronic version will be sent by email to AIC members in addition to the print newsletter by standard mail. The e-newsletter will contain the same content as the print *AIC News*; articles in the email will link to full-text versions on AIC's website. To ensure that you receive the electronic version, log in to www.conservation-us.org and check that the email address listed in your profile is up-to-date. We look forward to offering this additional member benefit!

Report from Erbil, Iraq

Dear Colleagues,

I write to thank all of you who have donated publications to the Iraqi Institute for the Conservation and Preservation of Antiquities and Heritage. Over the last year we have received over 200 books and periodicals from many generous individuals and institutions. The AIC office generously posted information about making donations on the AIC website drawing attention to our project. Our colleagues at the University of Delaware collected the books, attached a book plate (written in English, Arabic and Kurdish) and sent the books to us. These publications form the backbone of a conservation, historic preservation, and archaeology library that has recently moved to our new Institute building near the historic citadel in the center of Erbil.

You can see more specific information about the Iraqi Institute and the larger U.S. Embassy-funded project elsewhere in this newsletter (Worth Noting, pg. 12). However, I wanted to take an opportunity to give a more personal view into what the support of AIC members has meant to the Institute.

This project has been an amazing opportunity to meet Iraqi professionals who care passionately about their heritage. The students come from all over the country and live away from their families for weeks at a time. It has also been a wonderful opportunity to meet and work with individuals from around the world who have travelled to Erbil to work with my colleagues Brian Lione, Project Coordinator, and Rima al-Ajlouni, Project Director for Historic Preservation and Archaeology, to teach our students and share their expertise with other students and professionals through public lectures throughout the region.

Beyond that, I want you all to know how much easier you have made my work through constant professional support, ideas, teaching aids, and many other types of guidance through the last year. I am honored to bring some of the generosity of our conservation and heritage community to our colleagues in Iraq and show them how much you all care about

their history and their current lives.

As the Institute continues on with its evolving role in heritage preservation in Iraq I am certain that our community will support its goals and its professional staff. I invite any of you who have an interest in Iraqi archaeology, history, and culture to come visit us in Erbil. Bring us a book for the library and we'll give you a tour.

With profound thanks, Jessie.

—Jessica S. Johnson, Program Director,
Collections Conservation and Management Program, Iraq Cultural Heritage Project (IChP), International Relief and Development (IRD), Erbil, Iraq,
jsjohnson.ird@gmail.com

Bylaws Amendment

An AIC Bylaws vote will be held at the AIC Members Business Meeting, set for Thursday, May 13, from noon to 2:30 p.m.

The vote relates only to Section VII, which addresses how the Bylaws can be amended. Currently, this section states that only Professional Associates and Fellows attending the Members Business Meeting at the Annual Meeting are able to vote, potentially leaving Professional Associates and Fellows unable to attend the meeting disenfranchised. Records show that in the past two years just over one third of PA and Fellow members attended the annual meeting.

With electronic voting now common, it is possible to give the opportunity to vote on Bylaw revisions to all Professional Associates and Fellows. Following consultation with legal counsel, the AIC Board of Directors proposes the following amendment:

SECTION VII: AMENDMENTS

Current AIC Bylaws language:

These Bylaws may be amended, added to, or repealed by a vote of not less than two thirds of the Fellows and Professional Associates present in person at a General Meeting announced in accordance with the provisions of Section IV, paragraph 1, provided that notice of such changes has been furnished in writing to said membership.

Proposed amended language:

These Bylaws may be amended, repealed or altered, in whole or part, by a vote (including electronic vote) of not less than two thirds (2/3) of the Fellows and Professional Associates casting a vote at which a quorum is present (members who vote by electronic vote are deemed present). Notice of any proposed Bylaw change or changes must be furnished in writing (which may include an electronic transmission) to the members entitled to vote not less than thirty (30) days prior to the vote.

The AIC Bylaws Committee and staff are also examining other sections of the AIC Bylaws for revisions that may be proposed for a future vote to ensure that the AIC Bylaws are up to date and support the activities of the organization.

Please contact either Eryl Wentworth (ewentworth@conservation-us.org) or Ruth Seyler (rseyler@conservation-us.org) with any questions or comments prior to the vote.

FAIC News

Haiti Response Effort Update

FAIC has been working closely with the U.S. Committee of the Blue Shield (USCBS) to send AIC Collections Emergency Response Team (AIC-CERT) members to assist in Haiti. NEH, NEA, IMLS, and PCAH have committed funds for assistance. However, there are many “moving pieces” in this projected first international deployment for AIC-CERT, so please keep an eye on the AIC Website for latest news and updates.

The Andrew W. Mellon Foundation Award

The Andrew W. Mellon Foundation has awarded FAIC \$3.46 million to establish a photograph conservation lab at the Hermitage Museum in St. Petersburg, Russia. Paul Messier, outgoing member of the AIC Board of Directors, will serve as project manager on this four-year initiative. An Advisory

Committee has been created and includes Franziska Frey (Rochester Institute of Technology), Bertrand Lavédrine (Centre de Recherche sur la Conservation des Collections), Debra Hess Norris (University of Delaware), Robert Burton (Harvard University), and Eric Pourchot (FAIC), in addition to co-chairs Paul Messier and Viacheslav Fedorov, director of the History of Russian Culture Department, State Hermitage Museum. Angelica Rudenstine is serving as a consultant to the Mellon Foundation to oversee this major initiative.

FAIC will provide administration and financial oversight of the initiative, while assisting in professional development activities. Training opportunities for Russian colleagues, primarily undertaken in the United States, will include internships, travel to professional conferences, academic programs and workshops, and sessions conducted using distance-learning applications. Laboratory equipment and materials will be purchased in the U.S. and shipped to the Hermitage Museum. Additional information about this initiative and updates will be provided regularly in the newsletter and on the website.

Annual Meeting and IIC/AIC Roundtable Grant Awards

The Samuel H. Kress Foundation has awarded FAIC \$2,750 toward international travel expenses for two speakers at the 2010 Annual Meeting in Milwaukee.

Additional funding has been secured for *The Plus/Minus Dilemma: A Way Forward in Collections Environmental Guidelines*, an international roundtable to be presented at the Annual Meeting in partnership with IIC. Grant funding for the Roundtable includes \$6,000 from the Institute of Museum and Library Services, \$3,000 from the Samuel H. Kress Foundation, and \$2,500 from the Booth Heritage Foundation (with another \$2,500 toward the IIC Istanbul Roundtable program). Tru Vue is also a sponsor of the event.

AIC Board Elections

Thank you to all members who voted in the recent election for directors and officers of the AIC Board. Your vote is critical in maintaining strong leadership for our organization. Election results will be announced at the Members Business Meeting on May 13 in Milwaukee.

FAIC Video Art Workshop Receives NEA Support

FAIC and EMG are pleased to announce a two-day workshop, “TechFocus I: Caring for Video Art,” to take place September 1-2, 2010 at the Guggenheim Museum in New York, in conjunction with the exhibition, *Haunted—Contemporary Video, Photography and Performance*. Supported by a \$25,000 grant from the National Endowment for the Arts (NEA), this inaugural workshop begins a planned series of four workshops on the preservation and presentation of electronic art, acknowledging the 10th anniversary of the ground-breaking “TechArchaeology” symposium.

This event aims to acquaint participants with the technical functionality of both analog and digital video art as well as the technical and aesthetic impact of digitization, compression, and format migration. A comparative “school of seeing” will be offered to sensitize the participant’s eye for image structure and quality. The second day sessions will focus on the varieties of display modes of video art in an exhibition context and demonstrate the impact of equipment selection on the integrity of the artwork. Curators, conservators, and technicians will provide insight into their decision-making processes and discuss their perspectives on the variability of video art installations.

The program is organized by the AIC Electronic Media Group. Thanks to Christine Frohnert, Joanna Phillips, Agathe Jarczyk, Martha Singer, Dara Meyers-Kingsley, Carol Stringari, Fletcher Durant, and Gwynne Ryan for their service on the planning committee. More information and registration details can be found at www.conservation-us.org/courses or by contacting AIC at 202-452-9545.

FAIC Scholarships and Grants Awarded

The following individuals received **FAIC Individual Professional Development Scholarships** in the February awards cycle, listed here with their funded projects:

Rita Albertson: Cleaning 2010, New Insights into the Cleaning of Paintings

Wendy Bennett: FAIC Workshop Artist Pastels: History & Use

Ellen Carrlee: ICOM-CC WOAM Conference

Christina Milton O'Connell: Cleaning 2010, New Insights into the Cleaning of Paintings

Leslie Paisley: ICCROM Conservation of Japanese Paper course

Camilla van Vooren: Cleaning 2010, New Insights into the Cleaning of Paintings

Two additional awards were made for **FAIC NEH Individual Professional Development Scholarships**:

Cricket Harbeck: Conservation of Outdoor Sculpture

Jennifer McGlinchey: Characterization of Silver Gelatin Photographs

Three awards were made from the **Carolyn Horton Fund**:

Nita Greene: FAIC Mastering In-painting workshop

Laura O'Brien Miller: AIC Annual Meeting

Georgia Southworth: AIC Annual Meeting

One award was made from the **Christa Gaehde Fund to Victoria Binder** to present a talk at the AIC Annual Meeting.

FAIC Lecture Grants were made for three projects:

Michele Phillips, Waterford, New York: "What's Your Biggest Problem? Re-discover the inspiration you derive from your collections by getting a handle on their care"

Cape Fear Museum, Wilmington, North Carolina: "Caring for Wood"
Portland Art Museum, Portland, Oregon: "What is Art Conservation?"

No award was made in the "Take a Chance" grant program this year. The next deadline for FAIC/NEH Professional Development Scholarships is September 15, 2010. Guidelines and application forms are available on the AIC website at www.conservation-us.org/grants.

FAIC Samuel H. Kress Conservation Publication Fellowships Awarded

Two FAIC Samuel H. Kress Conservation Publication Fellowships were awarded for 2010. The Fellowships are designed to provide time off from other duties so that authors can complete book-length manuscripts of value to the conservation profession.

Barbara Appelbaum received a Fellowship to complete her work, *A Guide to Preservation of Collections*. The book will be a general reference for both conservators and custodians of all kinds of collections. The book's first section describes the decision-making processes involved in institutions' long-term preservation activities, with an emphasis on conservation assessments. The second section will provide the background information needed to make those decisions, including information on environmental issues, "going green," and safety.

Ms. Appelbaum is a conservator in private practice in New York City, and has been conducting museum assessments since 1975. Her first book, *Guide to Environmental Protection of Collections*, was published by Sound View Press in 1991. She received a FAIC Samuel H. Kress Foundation Conservation Publication Fellowship in 1996 to complete *Conservation Treatment Methodology*, published by in 2007 by Elsevier.

The second Fellowship was awarded to **Sylvie Pénichon** for her manuscript on "Care and Identification of 20th Century Color Photographs." Despite the large number of color photographs in collections today,

very little has been published on the multiple processes used during the 20th century. Her book will provide a reference tool that provides, in a clear and simple way, basic information on how to identify and care for color photographs.

Ms. Pénichon began her career as a commercial photographer in 1981 and, since 1998, as a conservator of photographs. She has been conservator of photographs at the Amon Carter Museum in Fort Worth, TX, since 2002.

FAIC has awarded 36 Conservation Publication Fellowships since 1994. Of the 26 completed manuscripts, 13 are currently in print and six more are expected to be published shortly.

—Eric Pourchot, Institutional Advancement Director, FAIC

Allied Organizations

HERITAGE PRESERVATION

Stormy Weather

The Atlantic Coast hurricane season begins on June 1, 2010, and meteorologists are forecasting an active season. Earthquakes in Haiti and Chile and this year's serious spring flooding in the U.S. remind us that preparedness is paramount. The Heritage Emergency National Task Force Web site has useful tools for disaster preparedness and response for cultural heritage. See the Quick Links at www.heritageemergency.org. Should a major region-wide emergency occur, the Task Force will monitor damage and provide resources for cultural institutions on the "Information on Major Disasters" Web page: www.heritagepreservation.org/programs/TFcurrent.html.

Join the MayDay Movement!

There is still time to participate in this year's campaign. Sponsored by Heritage Preservation and other members of the Heritage Emergency National Task Force, MayDay promotes emergency preparedness in cultural institutions. Visit Heritage Preservation's MayDay Web page to learn about the simple steps museums

and libraries are taking this spring: www.heritageemergency.org. Submit your own MayDay activity and be entered in a drawing to win disaster supplies. MayDay stories will be accepted until May 21, 2010, and prize-winners will be announced on June 1, 2010.

AMERICAN ASSOCIATION OF MUSEUMS (AAM)

AAM Unveils Annual Meeting Virtual Conference

AAM is unveiling a virtual conference to deliver educational content live from its 2010 Annual Meeting in Los Angeles on May 24–25, 2010. The Virtual Conference, produced in collaboration with LearningTimes, is a two-day online conference showcasing nine sessions selected by AAM's Standing Professional Committees that have the broadest appeal and greatest relevance to their constituencies. The sessions cover a wide range of museum issues to include: innovative technology that keeps visitors connected, creating experiences for "Millennials," and the promise and peril of using volunteers to help personalize visitors' experiences. For details on this exciting program, please visit the Virtual Conference site, <http://aam-us.org/am10/virtualconference2010.cfm>.

AMERICAN LIBRARY ASSOCIATION (ALA)

Pass It On!—ALA and AIC

Memories and treasures should last a lifetime and be passed on to future generations. The first national collections Preservation Week, "Pass It On!," will take place May 9–15, 2010. Sponsored by the ALA's Association of Library Collections and Services and partner organizations, Preservation Week will inspire actions to preserve personal, family, and community collections, in addition to library, museum, and archive collections. It will also raise awareness of the role libraries and other cultural institutions can play in providing ongoing preservation information. Local institutions are asked to do one thing in their communities to celebrate Preservation

Week, even if the action or activity is small. For more information, visit www.ala.org/preservationweek.

AIC is a partner in this important initiative. We ask you to promote Preservation Week activities in your community and to send your stories to Brett Rodgers at brodgers@conservation-us.org so that we can publicize your preservation success stories.

COLLEGE ART ASSOCIATION (CAA)

2010 AIC-sponsored Workshop at CAA Annual Meeting

In February 2010, twenty-nine CAA members had the rare privilege of studying a dozen Winslow Homer watercolors at the Art Institute of Chicago, guided by curator Martha Tedeschi and conservator Christie Daum. The curator and conservator had worked closely together prior to the recent exhibition of Homer watercolors when Tedeschi told Daum about the question she always hears from artists who have come to see these watercolors: "How did Homer do them?" Prompted by this challenge, Daum attempted to recreate them and figured out some of the technical details that Homer used to modify the paper itself. Further technical information is available on the museum's website, including interactive images which allow the user to add color to faded watercolors: www.artic.edu/aic/collections/exhibitions/homer/behindscenes.

The workshop was organized by AIC member Rebecca Rushfield who is already planning another workshop for the 2011 meeting in New York, for which attendance will be allowed by pre-registration only. If you want information about the New York workshop, contact her after September at wittert@juno.com.

—Andrea Kirsh, Philadelphia, PA

New Publications

New Publication

Information on a new series of publications called "Smithsonian Contributions to Museum

Conservation" is available at www.sil.si.edu/smithsoniancontributions. Number 1 in the series is entitled *Pesticide Mitigation in Museum Collections: Science in Conservation: Proceedings from the MCI Workshop Series* (March 2010). Visit the site to view the full announcement and find links to the downloadable PDF.

—Ann N'Gadi, reprinted from the *Conservation DistList Instance 23:35*

The Nicolas: Restoration Tales in a Family History, by Armando Brignolo and Salvatore Giannella, contains personal and professional recollections by a family of restorers based near Turin. 143 pages. Turin, Italy: U. Allemandi, 2009.

Printed on Paper: The Techniques, History and Conservation of Printed Media, edited by Jane Colbourne, contains the revised and edited text of papers presented at the 2007 Printed on Paper conference at the Sage Gateshead, jointly organized by Northumbria University and AIC. 236 pages. Newcastle: Northumbria University, 2009.

Research in Book and Paper Conservation in Europe: A State of the Art, edited by Patricia Engel, offers both practical and theoretical perspectives on book and paper conservation. 328 pages. Vienna: Verlag Berger Horn, 2009.

John Singer Sargent's Triumph of Religion at the Boston Public Library: Creation and Restoration, edited by Narayan Khandekar, Gianfranco Pocobene, and Kate Smith, is a collection of essays that describe the 2003–4 restoration project of Sargent's murals, and also includes information on the history of the murals, as well as the artist's methods and materials. 296 pages. Cambridge, MA: Harvard Art Museum; New Haven: Yale University Press, 2010.

Henk J. Porck's *Buntpapier: ein Bestimmungsbuch* is an illustrated guide to decorated papers, with entries in German, English, and Dutch. 217 pages. Hamburg: Buntpapierverlag, 2009.

Wrought in Gold and Silk: Preserving the Art of Historic Tapestries, by Anita Quye, Kathryn Hallett, and Concha Herrero Carretero, reports on research conducted by

the European Community-funded project Monitoring of Damage in Historic Tapestries (MODHT). 134 pages. Edinburgh: National Museums Scotland, in association with Historic Royal Palaces and Patrimonio Nacional, 2009.

The World's Heritage: A Complete Guide to the Most Extraordinary Places, produced by UNESCO, is an illustrated guide to cultural, natural, and mixed sites around the world, presented chronologically by the year in which they were inscribed on the World Heritage List. 832 pages. London: Collins, 2009.

The Nature of Conservation: A Race Against Time explains the place of conservation and restoration in museums. Long out of print, it is now available online by the Getty Conservation Institute (GCI). Access PDF files of the publication at www.getty.edu/conservation/publications/pdf_publications/nature_of_conservation.html.

—Sheila Cummins, *Research Associate for Collection Development*, Getty Conservation Institute, SCummins@getty.edu

People

Dr. Glenn Alan Gates has recently joined the Walters Art Museum as Conservation Scientist in its Division of Conservation and Technical Research in Baltimore, MD. His position is generously supported with funds from The Andrew W. Mellon Foundation. Previously, Glenn was the Head Research Scientist at the Detroit Institute of Arts. He also completed the Andrew W. Mellon Post-doctoral Fellowship at the Straus Center for Conservation under the direction of Dr. Narayan Khandekar, and worked in the scientific laboratories at the National Gallery of Art and the Los Angeles County Museum of Art.

Stephanie Hornbeck has left the Smithsonian's National Museum of African Art to open a private practice in object conservation (www.caryatid-conservation.com) in Miami, FL.

New Materials and Research

Refractive Index for Hxtal Correction

There has been some confusion concerning the Refractive Index of HXTAL NYL-1 epoxy. Recently the Refractive Index for Hxtal was listed as 1.549 on the website, www.Hxtal.com (HXTAL-NYL-1 technical Sheet). After inquiring further, it was determined that this was due to a mistake. It has now been corrected to 1.515.

—Stephen Koob, *Chief Conservator*, *The Coming Museum of Glass*, koobsp@cmog.org

Worth Noting

New Textile Conservation Center

The Textile Conservation Centre Foundation (TCCF) and the University of Glasgow have agreed to found the new teaching and research facility—the only resource of its kind in the U.K.—in the University's Robertson Building at the University of Glasgow.

The new Centre for Textile Conservation, History and Technical Art History will focus on multidisciplinary object-based teaching and research that encompasses conservation and the physical sciences, as well as art history and textile history. The new center will inherit existing library intellectual property and analytical equipment from the TCCF, so that staff and future students will be able to draw on the key physical and intellectual assets built up over more than 30 years. Students will also have the opportunity to work with the textile collections held by Glasgow Museums, the National Museums of Scotland, and the University's own Hunterian Museum and Art Gallery. New academic posts will be created and the center will work closely with the TCCF to establish a global research network in textile conservation, textile and dress history, and technical art history.

The first student intake is planned for September 2010, offering a 2-year

JAIC Publication Reviews

The editors of the *Journal of the American Institute for Conservation* are always looking for book reviewers to assess titles that have been published in recent years. Please contact Harriet Stratis, Book Editor, at hstratis@artic.edu, or Michele Derrick, Editor-in-Chief, at MDerrick@mfa.org for more information.

Masters in Textile Conservation and a 1-year Masters in History of Textiles and Dress, as well as opportunities for doctoral research. Potential students who would like to receive updates on the development and course details should email Ailsa Boyd at the University of Glasgow at A.Boyd@artist.arts.gla.ac.uk.

For additional information, contact Professor Nick Pearce, Director of the Institute for Art History and Head of the Department of History of Art, University of Glasgow Tel, 0141 330 3826. The university's website is www.glasgow.ac.uk.

New Graduate Program in Heritage Science

The University College London Centre for Sustainable Heritage is delighted to announce a new Masters program in Heritage Science. This interdisciplinary program aims to develop a broad understanding of state-of-the-art science and its application to conservation, interpretation, management, and access to cultural heritage among researchers and practitioners. The program is intended to appeal to science graduates and those who can demonstrate an aptitude for science. Three years' work experience or a minimum of 5 years' professional experience is desirable, with demonstrable experience in scientific research. The program includes a significant research component with intensively linked projects, field-based living laboratory, and the masters dissertation. It is delivered in a modular way and can be taken full time (1 year) or part time (2-5 years). For more information,

continued on page 12

Box 1. Conservation Reference Databases

Atlas of plant material & fibers from
New Zealand & the Pacific
www.otago.ac.nz/textiles/plantfibres/index.html

CAMEO: MFA Boston's Conservation and Art
Materials Encyclopedia Online
<http://cameo.mfa.org>

The Feather Atlas, database of scanned flight feathers
from North American Birds.
www.lab.fws.gov/featheratlas/index.php

Fiber Reference Image Library
<https://fril.osu.edu/>

Furskin Identification
www.furskin.cz

Insect Identification
www.museumpests.net/

Ivory Identification
www.lab.fws.gov/ivory.php

Pigments through the Ages, Database about the history,
manufacture, and chemistry of a selection of pigments.
www.webexhibits.org/pigments/

Wood Identification Atlas
<http://insidewood.lib.ncsu.edu/welcome>

DOWNLOADABLE CONSERVATION RESOURCES

Canadian Conservation Institute's CCI Notes, focused
leaflets on conservation and collections care topics.
www.cci-icc.gc.ca/crc/notes/index-eng.asp

CAT (Condition Assessment Tool)
Downloadable computer software program developed by
the Museums Galleries Scotland to help heritage organiza-
tions better care for their collections.
www.collectionslink.org.uk/conservate_objects/cat

ICON's Conservation Register
Brochures on caring for art, antiques and decorative archi-
tectural features for small institutions.
www.conservationregister.com

Marine Archaeological Conservation online manual:
Methods of Conserving Archaeological Material from
Underwater Sites.
<http://nautarch.tamu.edu/crl/>

National Park Service's Conserve O Grams,
Short, focused leaflets on caring for museum objects.
www.nps.gov/history/museum/publications/conservoogram/cons_toc.html

National Park Service's Museum Handbook
Reference guide on managing, preserving, documenting
and using museum collections.
www.nps.gov/history/museum/publications/handbook.html

PRESENTATION TOOLS

Faculte
Free service to add voice, record video, and annotate pow-
erpoints and images to create presentations, videos, and
talking slideshows. These can be emailed to clients, cura-
tors, or colleagues to share treatments or ask for input.
www.faculte.com

Zamzar
A free service for downloading and converting videos from
YouTube to view or put in presentations. Multiple formats
and sizes are available.
www.zamzar.com

ARTICLES AND BIBLIOGRAPHIES

AATA
Comprehensive database of over 100,000 abstracts of
literature related to the preservation and conservation of
material cultural heritage.
<http://aata.getty.edu/nps/>

AIC Wiki
Conservation catalogs and reference manuals converted to
wiki format. Include descriptions of materials and tech-
niques used to preserve and treat works of art and historic
artifacts.
www.conservation-wiki.com

BCIN
www.bcin.ca/English/home_english.html

Conservation Online (CoOL)
<http://cool.conservation-us.org/>

DistList Archives
<http://cool.conservation-us.org/byform/mailling-lists/cdl/>

Getty bibliographic database
Includes downloadable articles
<http://gcibibs.getty.edu/asp/>

JAIC Archive
<http://cool.conservation-us.org/coolaic/jaic/>

significantly changed today's research methodology from what it once was. Abundant online resources from reputable sources are readily available and increasing every day, and many may be accessed for little or no cost. There are a broad range of material-identification websites that exist, covering fibers, pigments, ivory, feathers, wood, fur, and plant material to name a few. Box 1 lists some of these websites.

Web 1.0

Access to static information is often grouped under the term "Web 1.0." These are sites that contain "read-only" material. Most of the content has been contributed by a few individuals, but can be downloaded by many. Often they contain printed information that was transferred or posted to the Internet. One example is the Canadian Conservation Institute's Preservation Framework Online, a digital outline generated from what was originally a printed wall chart. Online access to out-of-print resources is increasing and many current resources are now available electronically. Examples include issues of the *Journal of the American Institute for Conservation* (JAIC), *IIC Studies in Conservation*, and *Art and Archaeology Technical Abstracts* (AATA). More recent are materials created specifically for the Web without a printed counterpart. Among these is MuseumPests.net, a site created for integrated pest management with downloadable pest fact sheets containing images and identification aids. Although this site was conceived and functions within a collaborative structure, it serves a wider audience in its current downloadable format.

Web 2.0

Sites that facilitate user collaboration and interactive information sharing are typically grouped under the term "Web 2.0." Web-based applications allow users to generate and share content. The line between publisher and consumer becomes blurred as people contribute information in an uncomplicated and organic way.

The most widely used example is

the collaborative Web-based encyclopedia, Wikipedia. A wiki is a website that facilitates the easy creation and editing of interlinked pages. AIC is now participating in the Web 2.0 world with the recent creation of its wiki. This user-generated site, based on the specialty group catalogs, is designed to incorporate working knowledge of materials and techniques and provide a forum for easy addition, editing, and access to the resources. Wiki software also has the ability to use aggregators to search through external data stored elsewhere. For example, the conservation departments at The Metropolitan Museum of Art are developing a documentation and treatment report database using a semantic wiki program. This wiki augments the reports by incorporating data from JSTOR, as well as other bibliographic databases and museum websites. Semantic wikis and the semantic Web publish information in Internet languages that are specifically designed to add meaning to and describe the structure of online content. This added knowledge helps computers perform automated information gathering and research.

Web 2.0 resources can extend from sharing working knowledge to sharing useful raw data. Institutions conducting research can collaborate on a scale that extends their professional networks in an innovative way. Two Andrew W. Mellon Foundation pilot projects are successful applications of this concept. The Raphael Research Resource, an online database created by the National Gallery in London, is centered on ten Raphael paintings in the Gallery's collection and compiles primary art historical, technical, and conservation information. The resource is free and available online, and users have access to images such as high-quality photographs, cross sections, and radiographs. The database now incorporates Raphael paintings from over 25 institutions, with plans to add additional artists in the future. The Master of the Fogg Pietá ~ Maestro di Figline Project revolves around a database that focuses on a group of dispersed works by the Maestro di

Figline, a 14th century Italian painter. These panels may have originally come from the same altarpiece, but are now split internationally among museums and private collections. Much like the Raphael Research Resource, this database allows for the addition of technical information to improve the understanding of the artist's working practice and identify the similarities between panels. For example, Lauren Cox, post-graduate fellow at the Straus Center for Conservation, demonstrated its collaborative success at the 2009 ANAGPIC conference. She described the examination of an uploaded x-ray image of a panel painting from the Worcester Art Museum, in which a preparatory canvas layer was visible that was not evident on the radiograph of the Fogg's panel. Using Worcester's x-ray settings found on the database, she re-x-rayed their panel and confirmed the presence of a canvas layer.

Another prevalent form of online collaboration is social networking: Web-based services that allow users to connect and interact over the Internet to share ideas, activities, events, and interests within their individual networks. It is becoming a standard for museums to have blogs and be involved with social media applications such as Facebook, Twitter, Flickr, and LinkedIn. Box 2 includes definitions for many of these applications. Social media sites began as tools for keeping in touch with friends and posting activities and interests. Today, their power on a global and professional level has transcended these beginnings.

A core group of enthusiastic and energetic conservators has become active in the social networking world. There are several detailed conservation blogs with treatment information and links to online resources for conservators, as listed in Box 3. Some conservators use Twitter and Facebook to post treatment questions and event notifications, as well as photos and videos. Responses are generated in minutes or hours – regardless of geographic location.

Social media has transformed how information is generated and

Box 2. Glossary of Social Media Terms

For a good summary of how the National Center for the Preservation of Technology and Training uses social media applications, visit www.ncptt.nps.gov/how-ncptt-uses-social-media.

Aggregator – Software that combines Internet content, such as news headlines and blog posts, into one location for easy viewing. This reduces the time needed to check websites for updates and creates a “personal newspaper.”

Blog – Short for “web log.” A type of website, usually maintained by one individual, with regular entries of commentary, descriptions of events, or other material such as photos or video. Typically combines text, images, and links to other websites and blogs. (*v.* blog – to author an online chronology of thoughts. Usage: blogged, blogging; *n.* blogger)

Facebook – A social networking site where users can establish a personal profile page, connect and interact with friends and colleagues, and join networks organized by city, workplace, or school.

Flickr – A photo and video management and sharing website. Allows users to store and share photographs, as well as host images that are embedded in blogs and social media.

a. **Tag** – You can assign a “tag” to your uploads, which is similar to a keyword. Tags help you search and find common themes.

Metadata – Data about data. It can be applied to physical and electronic items such as books, CDs, DVDs, images, maps, and web pages. It can help organize rapidly growing volumes of data and information.

RSS Feed – A family of web formats used to publish and alert you to frequently updated works on blog entries, news headlines, audio, and video. It can include full or summarized text and metadata.

Semantic Web – Evolving development of the Web where the meaning (semantics) of information and services is defined, making it possible for the web to “understand” and satisfy requests.

Social Media – Media designed to be disseminated through social interaction. Often uses the Internet and web-based technology to transform broadcast media monologues into social media dialogues. Typically Internet-based applications that allow the creation and exchange of user-generated content.

Social Networking – Web-based services for users to connect and interact over the internet, share ideas, activities, events, and interests within their individual networks.

Twitter – A service that enables users to send and read messages (known as tweets) of 140 characters or less. Tweets are displayed on the author’s profile page and delivered to subscribers (known as followers). Can be accessed via the Twitter website or texts (SMS). Also called microblogging.

LinkedIn – A business-oriented social networking site that enables users to upload resumes and interests and to maintain a list of contact details of people they know and trust in business (known as connections). It is used to find jobs, people, and business opportunities recommended by someone in one’s contact network.

Web 1.0 – Websites that contain “read-only” material and static websites. Typically refers to the state of the Internet and any design style before 2001, with the collapse of the dot-com bubble.

Web 2.0 – Term commonly associated with web applications that facilitate interactive information sharing and user-centered design and collaboration, where people can consume as well as contribute information.

Web 3.0 – An as-of-yet undefined term for the future of the Web. Typically focuses on personalization, intelligent search, and behavioral advertising.

Wiki – An online database for creating, browsing, and searching through information. Used to create collaborative websites with interlinked web pages, such as Wikipedia.

shared, and conservators are on the cusp of applying this revolution to our field. It seems that the crucial change will occur when time management for online resources is conquered. Time spent in front of computers has increased, yet the same amount of treatment and research needs to be completed. The thought of adding more websites to check and more

places to post questions appears to be an insurmountable hurdle, but it does not have to be so.

Conservation websites, blogs, tweets, Facebook updates, and DistList postings are like specialty boutique shops; you have to go to many locations to acquire the information you seek. To save time, you need a store that carries all of the same items in one

location. Following and responding to social networking sites helps our profession develop and grow, but takes up more time than most people are willing to spend. How can we enable more conservators to join existing and future networks to collaborate on a scale that represents the size of our field?

Box 3. Conservation Blogs

This is a limited selection of blogs. Most bloggers have done a comprehensive job of assembling other conservation blogs, websites, databases, organizations, and online resources. Try searching through a few and compiling a list of useful websites for your specific needs.

Objects

Ellen Carrlee: <http://ellencarrlee.wordpress.com/>

Rose Daly: www.dalyconservation.com/

Book and Paper

Beth Heller: <http://bethhellerconservation.wordpress.com/>

Jeff Peachey: <http://jeffpeachey.wordpress.com/>

Holly Robertson: <http://doireallywanttotouchthat.wordpress.com/about/>

Museum Conservation Departments

Brooklyn: www.brooklynmuseum.org/community/blogosphere/bloggers/author/brunol/

The Indianapolis Museum of Art: www.imamuseum.org/blog/category/conservation/

Museum of Modern Art: www.moma.org/explore/inside_out/category/conservation (the comments are as informative as the posted content, read them as well)

for photos and video; perhaps an RSS Feed might be e-mailed based on user preference. Rather than searching multiple websites, all conservation information could be accessed from one location. All of this is possible today, given appropriate resources and the commitment to change how we choose to interact with web-based information sources.

Conclusions

Conservators are extremely proficient at taking existing technology and engineering a way to apply it to our complex field. Social networking programs, online education, and wiki software have proven to be functional and effective, and are examples of how we are currently using technology. Right now, we are still in the collaborative content-generating world of Web 2.0 and are transferring our collective knowledge online. As more content is added to the online community, we will increasingly rely on effective methods to quickly navigate through the information. Ultimately, the future of conservation and the Web lies with our ability to aggregate this information. Many of the tools exist today to do this effectively. With a collaborative effort, we can continue to energize and revolutionize the conservation field.

Note: this article is intended to provide a broad overview of Internet resources for conservators. For a more comprehensive and in-depth discussion of technological advancements, collaborative networks, and public interaction, an article by Richard McCoy, "Collaborating in the Public's Domain" is published by CeROArt and available online as a free download (<http://ceroart.revues.org/index1159.html>).

—Ariel O'Connor, arieloconnor@gmail.com

Acknowledgements:

I would like to express my sincere gratitude to Helen Alten, Chair, AIC Objects Group, for the original idea for this article, her continual thoughts and edits, and the opportunity to present the article in this forum. I would also like to thank Tim Huber and Carolyn Riccardelli for their editing assistance, and the friends and colleagues who contributed their innovative ideas and collaborative outlook.

Web 3.0

Currently, the Web allows for straightforward addition of knowledge, but the future lies in our ability to efficiently navigate through the expanses of online information. "Web 3.0" is a term used to describe the future of the Internet and the possibilities for controlling information. In the Web 3.0 world, information will be customized and personalized to help you access the data you want, when you want it. It is hoped that applications will run seamlessly on any electronic device and will be fast and customizable. Conceptually, the Internet will become one large database, and online searching will be tailored to specific users' preferences and needs. Visionaries theorize that Web 3.0 will extend into the physical; it will connect not only to your computer and smart phone, but also to your car,

kitchen appliances, and even your skin, making for an integrated experience.

How would this vision apply to conservation and our search for easier, quicker, more reliable information? Imagine, for example, a one-source information website. For example, the conservation field could endorse a semantic wiki that aggregates the online resources we frequently use. The wiki itself would be our user-generated encyclopedia, with information added and regulated by the conservation field. The wiki could search through other websites (CoOL, JSTOR, BCIN, AATA) and conservation blogs to pull in data from established resources. There could be a discussion and query component in which archived questions and conversations would automatically be included in a search. There could be an integrated media addition platform

Box 4. Google Custom Search Engine

A resource for those interested in quickly searching through specific information online is the Google Custom Search Engine (www.google.com/cse/). In less than five minutes, a free search engine can be created to search through the websites you specify. It is as easy as choosing a name and pasting in the addresses to as many websites as you want. For those with blogs, websites, or custom Google homepages, your search engine can be incorporated directly onto your site. For example, if you have a query and want to know if any of the conservation bloggers have addressed the question, simply create a search engine incorporating the addresses to their blogs. You can search through them instantly without sifting through the additional information you would get in a general Google search.

Continued from page 7

email the Heritage Science Course Director at m.strlic@ucl.ac.uk, or visit www.ucl.ac.uk/sustainableheritage/mres.html

—Reprinted from the *Conservation DistList*, Instance 23:34

Iraqi Institute for the Conservation and Preservation of Antiquities and Heritage

The Iraqi Institute for the Conservation and Preservation of Antiquities and Heritage opened the doors of its newly renovated building in Erbil Iraq, on March 14, 2010. The Institute building includes a conservation laboratory, a preservation/archaeology laboratory, a documentation laboratory, a large classroom, a lecture hall, and dormitory housing for about 28 students. Students will now live and work on site.

The initiative to begin the Institute was funded by the U.S. Embassy in Bagdad and is part of the Iraq Cultural Heritage Project (ICHP). The renovation and outfitting of the Iraqi Institute building was funded by the Kurdish Regional Government. International Relief and Development (IRD), a U.S.-based non-governmental organization specializing in working in conflict and post-conflict areas, implements the project for the Embassy.

Students of the Iraqi Institute are heritage professionals working for the State Board of Antiquities and Heritage. They come from all over Iraq to study in one of two programs: Collections Conservation and Management, directed by Jessica S. Johnson, and Preservation and Archaeology, directed by Dr. Rima al-Ajlouni. Brian Lione is the Project Coordinator for the project.

The core courses of the Institute are divided into modules of approximately 6 to 8 weeks (depending on the program). Expert faculty instructors in conservation and preservation come from all over the world to give the students the highest level of education possible, and bring the skills of Iraqi heritage professionals up to current international standards. Practical projects take place throughout Erbil through collaboration with other local heritage institutions. At the

end of each module, students return to work and carry out a practical project in their home institution in order to ensure recently learned skills are practiced immediately and applied to their real-life situations.

A large number of heritage professionals and other partners have contributed to the opening of the Iraqi Institute. Diane Siebrandt, Cultural Heritage Programs Manager in the Cultural Affairs Office at the Embassy oversees the project. Institutions advising on the program have included the University of Delaware Art Conservation Program, Winterthur Museums and Country Estate, the Walters Art Museum, and the National Park Service.

For more information about the ICHP program, see: <http://exchanges.state.gov/heritage/iraq.html>. For more information about the U.S. Embassy Baghdad, see: <http://exchanges.state.gov/heritage/iraq>.

—Jessica S. Johnson, Program Director, *Collections Conservation and Management Program, Iraq Cultural Heritage Project*

Museum Receives Archives from Archaeological Project in Peru

Since January, Peabody Museum staff and graduate students have been unwrapping and accessioning hundreds of maps, photographs, slides, field notes, and more from an archaeological project. The materials from Harvard's Chan Chan—Moche Valley Archaeological Project (CCMVP) have significant research value.

Declared a UNESCO World Heritage Site in 1986, Chan Chan is generally agreed to have been the capital of the Kingdom of Chimor, also known as the Chimu archaeological culture, which was one of the largest states or empires in Peru immediately before the rise of the Incas.

Once the documents have been accessioned, the Peabody will seek funds to digitize important documents and make them easily accessible via the Museum website. The Museum will be working cooperatively with Peruvian scholars and institutions to make materials accessible in both English and Spanish, continuing a long

Grant and fellowship opportunities are listed online at www.conservation-us.org/grantsandfellowships

tradition of cutting-edge research and partnerships to share its resources.

Read the complete press release about this project at www.peabody.harvard.edu/node/583

Critical Issues in Art Conservation Blog

For an undergraduate course “Critical Issues in Art Conservation” at the Johns Hopkins University, students participated via blog postings that reflected current course readings. The course looked at issues in the history, ethics, and contemporary practice of conservation, as well as how conservation changes art and artifacts and our interpretations of them. Students contributed to the blog, www.critical-issuesinartconservation.blogspot.com, and colleagues responded by posting comments about their blog entries.

It would be interesting and exciting to this group of dedicated and serious students if some of the authors of the course readings themselves engage with them on the blog and comment on their posts (a reading list is available on the site). Although the course itself will end in May, our hope is that the blog will become an interactive forum for the students, professional conservators, and the general public. New student posts appear every Monday, so please do check!

—Sanchita Balachandran, *Objects Conservation Studio, LLC*, sanchita@gmail.com, reprinted in part from the *Conservation DistList Instance 23:34*

Does Your Museum Transport Objects via Passenger Aircraft?

The Transportation Security Administration's (TSA) Certified Cargo Screening Program (CCSP) will be in effect for 100 percent of all air cargo by August 2010. Prepare now to safeguard your museum's artifacts in transit. The CCSP regulations require that all cargo shipped via passenger aircraft be screened at the piece level before shipment. This is similar to the screening of passenger baggage,

and could include instances of package opening and disassembly by TSA personnel if the shipment fails to pass initial methods of screening. In order to avoid significant delays in shipments or potential damage to objects, museums and other entities are encouraged to either ship items through a Certified Cargo Screening Facility (CCSF), or apply to become a CCSF themselves. CCSFs must meet stringent security standards specified by the TSA. Once certified, a CCSF is authorized to screen cargo at its own facility prior to packaging and delivery to freight forwarders or airlines. Museums that ship objects via passenger aircraft are encouraged to discuss this new regulation with their shipper or freight forwarder. Visit the TSA website for more information about the CCSP, www.tsa.gov/what_we_do/tsnm/air_cargo/programs.shtm#cert.

—from *AVISO*, 36:3 (March 2, 2010)

ANAGPIC and Other Training Programs

Columbia University Historic Preservation Program

The Columbia University 2009 Conservation Workshop class, directed by Mary Jablonski (PA) and George Wheeler (Fellow), focused its attention on Manitoga: The Russel Wright Design Center. Manitoga "...is the historic home, studio and 75-acre woodland garden of [the] preeminent American industrial designer Russel Wright..." Wright, best known for his ceramic and melamine resin dinnerware, is often credited with transforming American home life with the *A Guide to Easier Living*, published in 1950 and co-authored by his wife Mary. Manitoga was designated and National Historic Landmark in 2006 and was the recipient of a Save America's Treasures grant in 2002.

Traditionally, Columbia's Conservation Workshop class engaged with 18th and 19th century historic homes and sites. In recent years three important 20th century buildings provided new challenges for students: the George Wells house in Sturbridge, MA, Paul Rudolph's Orange County

Courthouse in Goshen, NY, and now, Manitoga.

The purpose of the workshop is to provide students with a hands-on experience that includes site and laboratory work such as documentation, sampling, instrumental analyses, field monitoring and evaluations, and mock-ups of conservation treatments. This information is analyzed and synthesized into a final report (see the program's website for recent reports: www.arch.columbia.edu/programs/historic-preservation). The purpose of the Historic Preservation Program workshop is to allow students access to first-rate architecture as well as owners to professional-level conservation experts.

For the fall 2009 workshop, Masters Degree candidates Ioannis Avramides, Laura Michela, Lisa Michela, Yuan Ren, Susan Shay, and Catherine Smith each selected a project based on the needs of the Manitoga site and their individual interests.

Among the most important initial conservation-related activities are archival research and environmental monitoring. In the case of Manitoga, and with the assistance of director Kitty McCullough and her staff, archival research consisted of not only the typical literature search, but also included a thorough review of files, old photographs and slides, and boxes of deinstalled window treatments – many not perused since Russel's death in 1976.

Environmental monitoring was performed in both the studio and the house, including temperature, relative humidity, and both UV and visible light levels. This monitoring, along with infrared thermal imaging, helped to explain mold growth on both interior woodwork and display items in the studio during colder periods in the fall.

Light played an important role in Wright's designs, with generous use of glass allowing southern and western sunlight to flood the interiors. At sites like Manitoga, conservators must balance the aesthetic of open modern buildings with protecting the collection. Color changes were noted and recorded on furniture upholstery, plastic panels, window drapes, and colored wall plasters. Current work at

the house will provide new mock-ups of damaged window treatments and assess their ability to reduce, alter, or block light. Steve Weintraub, president of Art Preservation Services, also provided a day-long session for the students at the site to talk about other solutions for reducing light damage.

Even the most casual reading of *A Guide to Easier Living* and awareness of Wright's dinnerware highlight his and Mary's central attention to the design and function of the kitchen/dining room areas of the house. The fusing of continuity and separation for the kitchen and dining rooms may be one of their most important contributions to late 20th century interior design, and Manitoga was the iconic proving ground for these ideas. Through the workshop class, the design, materials, and appliances (noting replacements) for this area of the house have been meticulously documented so that any planned conservation or restoration can draw from this material.

Finally, analyses of clear finishes in hallways and stairways of the house indicate that Wright employed both modern and traditional materials as both cellulose nitrate lacquers and copal-like resins were detected. The finishes study grew out of previous work carried out by Susan Buck and the thesis work of University of Pennsylvania/Historic Preservation Program student Christeen Taniguchi.

Columbia University Historic Preservation Program students will continue to monitor the site, work on implementing mock-ups, and carry out conservation treatments at Manitoga during the spring and fall of 2010. The Preservation Alumni group has planned a site assistance weekend during April 2010.

—George Wheeler and Mary Jablonski

Specialty Group Columns Now Online

The Specialty Group columns are now online. The columns are posted in the Specialty Group section of the AIC news blog, available at www.conservation-us.org/news or click on News on the website's left-side navigation bar.

COURSES, CONFERENCES, AND SEMINARS

2010 PROFESSIONAL DEVELOPMENT WORKSHOPS

The following courses are presented with funds from the FAIC Endowment for Professional Development, which is supported by The Andrew W. Mellon Foundation and by contributions from members and friends of AIC. Full descriptions and registration forms are available on the AIC website (www.conservation-us.org/courses) or from the AIC Office: (202) 452-9545, ext. 9.

THE FOUNDATION
OF THE
AMERICAN
INSTITUTE FOR
CONSERVATION
OF HISTORIC AND
ARTISTIC WORKS



FAIC WORKSHOPS

- **Mastering Inpainting** with Debbie Evans and Jim Bernstein, June 28–July 2, 2010, Shepherdstown, WV
- **Conservation of Outdoor Sculpture*** with various instructors, July 27–30, 2010, San Francisco, CA
- **Artist Pastels: History & Use** with Thea Burns, August 4–6, 2010, Buffalo, NY
- **Characterization of Silver Gelatin Photographs*** with various instructors, organized by Erin Murphy, September 30–October 1, 2010, New York, NY
- **New dates: Digital Imaging for Conservation and Museum Professionals*** with Dawn Heller and Tim Vitale, October 18–21, 2010, Wilmington, DE

*With financial support from the National Endowment for the Humanities, FAIC offers scholarships up to \$1,000 to help defray registration and travel expenses for participants in the FAIC workshops supported by NEH. All current AIC members who are U.S. residents or citizens are eligible. Special deadline: May 15. Regular deadline: September 15.

FAIC ONLINE COURSES

- **Mitigating Risk: Contracts and Insurance for Conservation** with Sarah Lowengard, June 3–July 1, 2010
- **Records and Information Management for Conservation** with Holly Robertson, July 29–August 26, 2010
- **Establishing a Conservation Practice** with Sarah Lowengard, September 16–October 14, 2010

FAIC CO-SPONSORED WORKSHOPS

- **Microscopy for Art Conservators** with Gary J. Laughlin, Ph.D., December 13–17, 2010, Chicago, IL. Presented by McCrone Research Institute.
- **Gilding Conservation**, June 21–24, 2010, Campbell Center, Mount Carroll, IL
- **Introduction to Organic Chemistry**, July 26–31, 2010, Campbell Center, Mount Carroll, IL
- **Pulp Repair Techniques for Paper Conservators**, September 1–4, 2010, Campbell Center, Mount Carroll, IL
- **Microscopy for the Identification of Pigments and Fibers in Art and Artifacts**, September 20–24, 2010, Campbell Center, Mount Carroll, IL
- **The Use of Bleaching Techniques in Paper Conservation**, September 27–October 1, 2010, Campbell Center, Mount Carroll, IL
- **Revealing Lost Content: Low-Tech Digital Forensics for the Bench Conservator**, September 30–October 2, 2010, Campbell Center, Mount Carroll, IL
- **Deacidification of Paper**, October 4–8, 2010, Campbell Center, Mount Carroll, IL

CALL FOR PAPERS

October 25–27, 2010. The Surface Metrology Lab at Worcester Polytechnic Institute, Second International Conference on Surface Metrology, Worcester, MA—Contact: www.surfacemetrology.org. Abstracts accepted until August 31, 2010.

February 3–5, 2011. Interdisciplinary Conference on the Practice of Salt Reduction, Hildesheim Germany—Contact: schwarz@hornemann-institut.de. Abstracts accepted until May 15, 2010.

October 17–22, 2011. CCI Symposium 2011: Adhesives and Consolidants for Conservation, Ottawa, Canada—Contact: www.cci-icc.gc.ca/symposium/2011/index-eng.aspx

GENERAL

May 5–6, 2010. 2nd International Mountmakers Forum, Smithsonian Institution, Washington, D.C.—Contact: Shelly Uhler, uhlirs@si.edu

May 21–22, 2010. 15th Annual American Art Conference, New York, NY—Contact: lisa.koenigsberg@artinitiatives.com, www.acteva.com/go/renewal

May 23–26, 2010. “Museums Without Borders,” AAM Annual Meeting, Los Angeles, CA—Contact: www.aam-us.org

May 24–26, 2010. YOCOCU – YOUTH in the CONSERVATION of CULTURAL HERITAGE, Palermo, Italy—Contact: www.yococu.com, info@yococu.com

COURSES, CONFERENCES, AND SEMINARS

May 25-26, 2010. The Tectonics of Digital Curation: A Symposium on the Shifting Preservation and Access Landscape. The Ray and Maria Stata Center, Massachusetts Institute of Technology (MIT), Cambridge, MA—Contact: www.nedcc.org

May 27, 2010. Third International Workshop on Image Processing in Art Investigations, MoMA, NY—Contact: www.digitalpaintinganalysis.org/IP4AI3/

May 31-June 1, 2010. “Biodiversity, 2010 and beyond, science and collections, 25th anniversary!,” SPNHC, Ottawa, Canada—Contact: http://140.247.98.87/?q=announcements/annual_meetings.html

June 7-8, 2010. International Masterclass: Dry Cleaning Methods, Netherlands Institute for Cultural Heritage (ICN), ICN Ateliergebouw Amsterdam—Contact: www.icn.nl/en/actueel/agenda/masterclass-dry-cleaning-june-2010

June 10, 2010. CAC Annual Conference, Ottawa, Canada—Contact: james.hay@pch.gc.ca, amanda.gould@civilization.ca

June 30-July 3, 2010. Chemistry for Cultural Heritage Conference, Ravenna, Italy—Contact: www.euchems.org/Divisions/Heritage/index.asp

July 12-16, 2010. INTER/MICRO 2010, Chicago, IL—Contact: 312-842-7100, intermicro@mcri.org, www.mcri.org

August 21-25, 2010. International Foundation for Cultural Property Protection 12th Annual Conference, Seminar, Exhibits & Certification Program, San Francisco, CA—Contact: 800-257-6717, www.ifcpp.org

September 13-16, 2010. International Masterclass: Plastics, Netherlands Institute for Cultural Heritage (ICN), ICN Ateliergebouw Amsterdam—Contact: www.icn.nl/en/actueel/agenda/masterclass-plastics-sept-2010

September 15-19, 2010. ICON Ethnography Group Workshop and One-Day Conference: Basketry Conservation, London, UK—Contact: basketry.reg@googlemail.com, www.icon.org.uk/index.php?option=com_content&task=view&id=112&Itemid=

September 19-23, 2010. ICOM-CC 16th Triennial Conference, Lisbon, Portugal—Contact: www.icom-cc2011.org

September 23-25, 2010. The Best in Heritage conference, Dubrovnik, Croatia—Contact: chf@thebestinheritage.com, www.TheBestinHeritage.com

September 20-24, 2010. IIC Congress 2010: Conservation and the Eastern Mediterranean, Istanbul, Turkey—Contact: iic@iiconservation.org

September 22-25, 2010. AASLH Annual Meeting, Oklahoma City, OK—Contact: www.aaslh.org

October 6-9, 2010. Association of Midwest Museums and Ohio Museum Association joint 2010 conference, Museum Making Connections, Cleveland, OH—Contact: www.midwestmuseums.org

November 7-13, 2010. ICOM Triennial Meeting, “Museums for Social Harmony,” Shanghai, China—Contact: www.icom-cc.org/52/event/?id=76

November 19-20, 2010. International Symposium on Heritage Recording and Information Management in the Digital Age (SMARTDoc Heritage), Philadelphia, PA—Contact: Suzanne Hyndman, 215-746-6441, www.smartdocheritage.org

ARCHITECTURE

September 22-24, 2010. 2nd Historic Mortars Conference, Prague, Czech Republic—Contact: hmc2010@itam.cas.cz, +420 283880458

BOOK AND PAPER

July 8-10, 2010. Sixth Islamic Manuscript Conference, Central Asian Islamic Manuscripts and Manuscript Collections, University of Cambridge, U.K.—Contact: Fax: +44 1223 302 218, tima@islamicmanuscript.org

OBJECTS

May 24-29, 2010. The 11th ICOM-CC Wet Organic Archaeological Materials Working Group (WOAM) Conference, Greenville, NC—Contact: Kristiane.straetkvern@natmus.dk, www.woam2010.com/index.htm

June 24-26, 2010. Archaeological Iron Conservation Colloquium in Stuttgart, Germany—Contact: www.iiconservation.org/events

July 15, 2010. In situ technical imaging for art and archaeology: a symposium in conservation science, London, U.K.—Contact: imaging@bm-mellon-symposia.org.uk

October 3-6, 2010. Interim Meeting of the ICOM-CC Glass and Ceramics Working Group, Corning, NY—Contact: Gerhard Eggert, coordinatorwgglassceramics@googlemail.com

October 8-9, 2010. ICOM Specialists Meeting on Enamels Conservation, New York City, NY—Contact: Agnes Gall-Ortlik, gallortlik@yahoo.fr, <http://icom.museum/calendar.html>

October 11-15, 2010. Metal 2010, Interim Meeting of the ICOM-CC Metal Working Group, Charleston, SC—Contact: 843-744-2974 ext. 20, Inasane@clemson.edu or www.metal2010.org

Please note, individual course listings are now listed once a year in print. Complete CCS listings and institutional contact info are available online at www.conservation-us.org/ccs

COURSES, CONFERENCES, AND SEMINARS

Board Meeting and IAG

The dates for the November AIC board, FAIC board, and IAG meetings have been set. They will take place Thursday through Saturday, November 11-13, 2010. More information and details will be announced when available.

October 28-29, 2010. Scientific Research in the Field of Asian Art: Topics in Ancient Metallurgy, Washington, DC—Contact: dcsr@si.edu

PAINTINGS

September 16-18, 2010. ICOM-CC Paintings Group Workshop: Current Practice and Recent Developments in the Structural Conservation of Paintings on Canvas Supports, Finland—Contact: tannar.ruuben@metropolia.fi

PHOTOGRAPHIC MATERIALS

May 27-28, 2010. 4th International Conference on Preservation and Conservation Issues in Digital Printing and Digital Photography, London—Contact: Lauren Stacy, lauren.stacy@iop.org, www.iop.org/Conferences/

October 19-22, 2010. ICOM-CC's Photographic Materials Group Interim Meeting, Athens, Greece—Contact: c.waldthausen@planet.nl

RESEARCH & TECHNICAL STUDIES

July 1-3, 2010. Chemistry for Cultural Heritage (ChemCH), Ravenna, Italy—Contact: www.socchimdabc.it/pages/OrgDivis.htm

September 9-10, 2010. SEM and Microanalysis in the Study of Historical Technology, Materials and Conservation, British Museum, London—

Contact: www.incca.org, incca@icn.nl

NEW COURSE OFFERINGS

George Eastman House
Rochester, NY

Tracing the Light: Imagery before Photography (June 14 - June 17); 1839: Processes of Daguerre, Talbot and Bayard (July 19 - July 22); Dawn of Photography (August 9 - 13); Digital Family Photographs: Printing, Sharing & Archiving (August 28 - 29); The Albumen Print: History & Technique (September 13 - 15); How to Identify and Preserve Historic Photographs: Part I, the 19th Century (October 16 - 17, 2010); The Platinum Print: History & Technique (November 13 - 14).
Contact: www.eastmanhouse.org/Main/events/series/photo-workshops

AIR-SAFE®

EFFECTIVE, AFFORDABLE, CASE MICRO-CLIMATE CONTROL
The perfect complement to NoUVIR's pure-white, stone-cold, zero UV, zero IR lighting!

Actual data log from AIR-SAFE protected case.

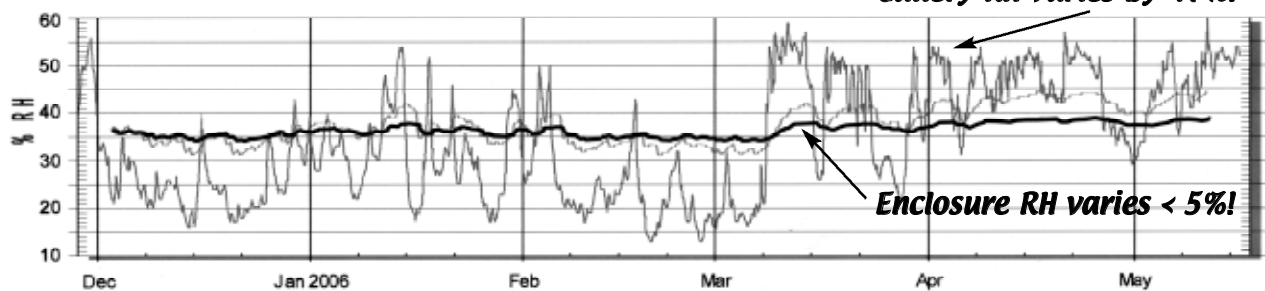

AIR-SAFE is...

- *Passive - requires no power or plumbing.*
- *Positive - cycles entire case volume every 72 hours.*
- *Easy to install - works with any normally sealed case.*
- *Eliminates all museum pollutants - chemical and particulate.*
- *Low cost - \$495.00 complete.*

Call for details

NoUVIR RESEARCH®

(302) 628-9933

or visit www.nouvir.com

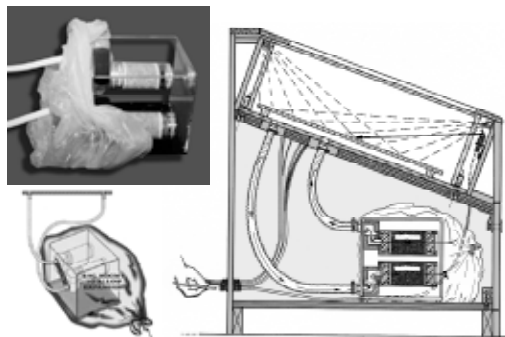

POSITIONS, INTERNSHIPS, AND FELLOWSHIPS

LIBRARY OF CONGRESS

Chemist – Research & Testing Division

Located on Capitol Hill, The Library of Congress is the nation's oldest federal cultural institution and the world's largest library. We currently have an opportunity for a Chemist in our Preservation Research & Testing Division.

The Chemist will contribute to the Library's preservation research program and works only under the most general supervision of the Chief of the Preservation Research and Testing Division. Work is performed with a high degree of independence and originality with little if any technical guidance. Scientific contribution made by the incumbent has significant potential for influencing the preservation of library and archival collections worldwide.

Candidates must have a degree in physical science, life sciences, or engineering in addition to knowledge of state-of-the-art chemical, physical, and/or engineering methods of analysis. Knowledge of current preservation research in the field of cultural heritage or material science is also highly recommended. Application deadline is 05/21/2010, Vacancy #100066.

Further details about the requirements and duties for this position, along with information on how to apply, may be found at www.loc.gov/hr/employment/index.php/. The Library of Congress is an EOE/AA Employer.

NATIONAL GALLERY OF ART

Scientist

The National Gallery of Art is pleased to announce the establishment of a Scientist position, which has been made possible through the generous support of the Andrew W. Mellon Foundation. The Gallery is seeking applications from qualified candidates to conduct research on photographic materials in support of the newly established Photograph Conservation Department and the

Gallery's expanding acquisition, exhibition, and educational programs. The scientist will work closely with Gallery scientists to identify research priorities related to the Gallery's photograph collections, collaborating with Gallery conservators, curators, other Gallery staff, and partner institutions to advance scientific and historical scholarship related to the science and conservation of photographic materials.

Eligibility: Candidates must be U.S. citizens or lawful permanent residents with a Ph.D. or equivalent training in one of the physical sciences, preferably chemistry, with prior experience and well-developed knowledge of the use of spectroscopic techniques, especially X-ray fluorescence spectrometry and Fourier-transform infrared spectrometry. Experience in gas chromatography, high-performance liquid chromatography, mass spectrometry, and other methods for scientific analysis of compounds and related materials found in works of art is also highly desirable. Candidates must demonstrate excellent communication and organizational skills; those with hands-on experience in traditional chemical methods of photography are preferred.

Application Procedure:

Interested Candidates must provide the following materials:

- A curriculum vitae with basic biographical information, current and permanent addresses, telephone numbers, a description of current and previous scientific experience, and three references with contact information.
- A statement, not to exceed 1000 words, of interest and intent in applying for the position.
- Offprints of no more than four publications highlighting relevant experience

Formal applications and supporting materials must be transmitted via email and sent by U.S. Postal Service or an express mail service for delivery by no later than 14 May 2010 to: Michael Skalka, Conservation Administrator, Conservation Division, National Gallery of Art, 2000B South Club Drive, Landover, MD 20785,

U.S.A., dcl@nga.gov

Guidelines for electronic application submission may be obtained by emailing Michael Skalka at the address above. All applicants will be notified by 15 June 2010 of the decision of the selection committee.

ST. MARK FINE ARTS CONSERVATION AND RESTORATION

Conservator

St. Mark Fine Arts Conservation and Restoration in Houston, Texas has an opening for a full-time conservator. Candidate should have ability in treatment of fine arts (paper a plus). For further information, please contact Mercedeh at 713.526.2302, or mercedeh@stmarkconservation.com

YALE UNIVERSITY ART GALLERY

Graduate Fellowship

The Yale University Art Gallery is seeking applications for a graduate fellowship beginning in September 2010 and running through the summer of 2011.

The department is conserving murals and ceiling paintings from the former Huntington mansion, planned for installation in renovated galleries of the Yale University Art Gallery. The works include 31 pieces -- 28 lunettes and 3 ceiling paintings, all of which were donated to Yale in 1926 by Archer Huntington, son of railroad magnate Collis Huntington.

Two ceiling paintings will be installed in the ceiling of the American Decorative Arts Galleries. The lunettes will adorn the American Paintings and Sculpture Galleries, the larger ones displayed in such a way as to reflect their original installation in the Huntington mansion. The smaller paintings will be integrated into the installation.

The murals have been stored at the Yale Art Gallery for many years and are in need of treatment in order for them to be exhibitable. Harsh removal techniques and inferior initial

POSITIONS, INTERNSHIPS, AND FELLOWSHIPS

storage caused damage that requires extensive treatment.

The work will be carried out in the Conservation Studio of the Yale University Art Gallery, currently located off-site from the museum in Yale's Library Shelving Facility, which house much of the Gallery's collection, the Visual Resources Department, and part of the Installations Department.

Candidates must be enrolled in, or have completed a conservation training program, or have equivalent experience, and be legally entitled to work in the United States. Stipend for the nine-month position is \$25,000, plus benefits. Given that the Conservation Lab is off-site, it would be preferable for the employee to have a car or bicycle.

Please submit the following no later than June 1, 2010:

- 1) Cover letter describing career goals and why this position is of particular interest to you
- 2) CV
- 3) Contact information for three professional references (letters not necessary)
- 4) Interview with portfolio will be required

Applications should be sent to Patricia Sherwin Garland, Senior Conservator of Paintings, Yale University Art Gallery, P.O. Box 208271, New Haven, CT 06520-8271 or patricia.garland@yale.edu

All candidates applying for positions at the Yale University Art Gallery will be subject to pre-employment screening. All offers are contingent upon the successful completion of a background check

YALE UNIVERSITY ART GALLERY

Graduate Fellowship

The Yale University Art Gallery Conservation Department is seeking applications for a graduate fellowship in objects conservation beginning in September 2010 and running through the summer of 2011.

The Department is conserving objects from its diverse collections to be installed in renovated

galleries of the Yale University Art Gallery. The collections include Ancient Art, Asian Art, African Art, Indo-Pacific Art, Early European Sculpture, American Decorative Arts, Furniture, and Sculpture, and Modern and Contemporary Art. Some of the collection objects have been in storage for decades, some have never been displayed, and some are recent acquisitions. Technical research is encouraged as part of the treatment processes.

The work will be carried out at the Yale University Art Gallery's off-site facilities: Yale's new West Campus Facility and the Library Shelving Facility, which houses much of the Gallery's collections, the Visual Resources Department, and part of the Installations Department.

Candidates must be enrolled in, or have completed a conservation training program, or have equivalent experience, and be legally entitled to work in the United States. Stipend for the twelve-month position is \$24,000, plus benefits. Given that the Conservation Labs are off-site, it would be preferable for the employee to have a car or bicycle.

Please submit the following no later than June 1, 2010:

- 1) Cover letter describing career goals and why this position is of particular interest to you
- 2) CV
- 3) Contact information for three professional references (letters not necessary)
- 4) Interview with portfolio will be required

Applications should be sent to Carol Snow, Objects Conservator, Yale University Art Gallery, P.O. Box 208271, New Haven, CT 06520-8271 or carol.snow@yale.edu.

All candidates applying for positions at the Yale University Art Gallery will be subject to pre-employment screening. All offers are contingent upon the successful completion of a background check.

THE MENIL COLLECTION Samuel H. Kress Fellowship in Paper Conservation

The Menil Collection is pleased to offer a one-year advanced fellowship in paper conservation supported by a grant from the Samuel H. Kress Foundation. The fellowship will provide an opportunity for participation in all departmental activities associated with a diverse and distinguished collection of 20th century and contemporary art, including drawings, photographs and prints. The fellow will also contribute to the development of the conservation component of the Menil Drawing Institute and Study Center, established in 2008 and dedicated to the collection, exhibition and study of modernist drawing. As an integral part of the department, the candidate must have an interest in the variety of issues associated with the study, documentation, and care of such a collection.

The fellowship will commence in the fall of 2010. Compensation will include a stipend and all benefits granted to full-time employees of the Menil. Candidates should be recent graduates of a recognized training program or have equivalent experience and they should have excellent communication skills. Applications should include a curriculum vitae with e-mail address and telephone number(s), a letter of intent, and the names and contact information for three professional references. Initial interviews will commence the week of May 10 and will take place at the AIC annual meeting in Milwaukee, when possible.

Suzanne Maloch
Manager of Human Resources
The Menil Collection
1511 Branard St.
Houston, Texas 77006 USA
Email: smaloch@menil.org
Phone: 713-525-9407

For more positions,
internships, and fellowships, visit
us online at
www.conservation-us.org/jobs

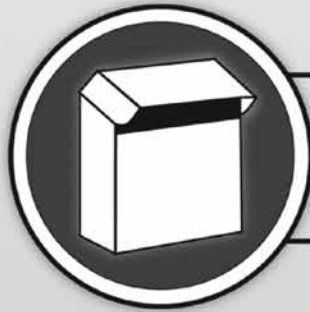

HOLLINGER METAL EDGE

Archival Storage Materials

The Choice for Archival Storage Solutions

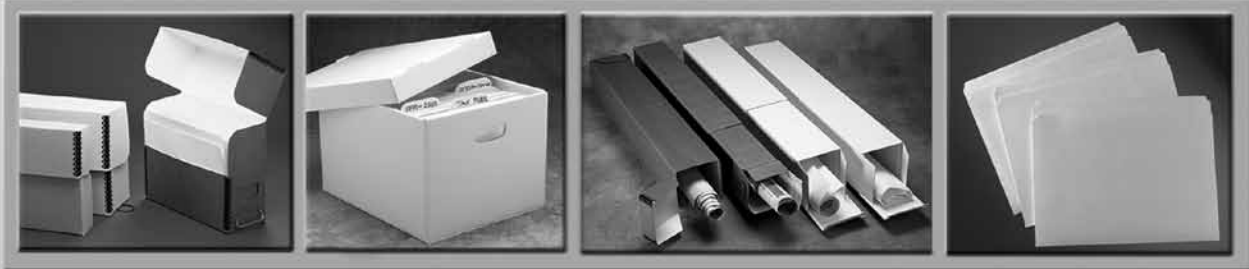

THE QUALITY SOURCE

hollingermetaledge.com

1•800•862•2228 or 1•800•634•0491

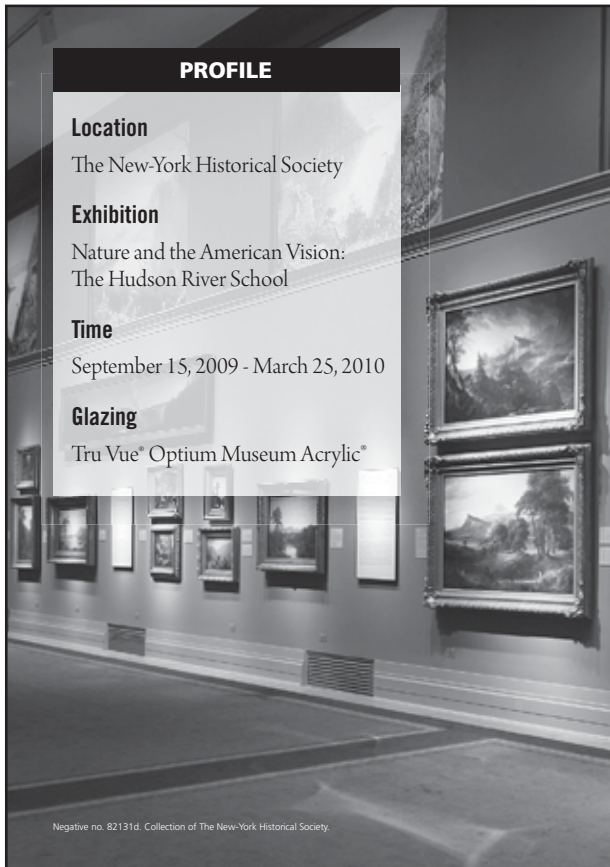

PROFILE

Location

The New-York Historical Society

Exhibition

Nature and the American Vision:
The Hudson River School

Time

September 15, 2009 - March 25, 2010

Glazing

Tru Vue® Optium Museum Acrylic®

Negative no. 82131d. Collection of The New-York Historical Society.

The Finest Collections Depend on Optium® Acrylic Glazing

When visitors experience an exhibit, it is vital that each piece is protected without compromising the aesthetics. With Optium® Acrylic Glazing from Tru Vue, you can achieve such an experience.

Optium combines the best of both worlds, anti-reflective safety glass and UV filtering acrylic, in one product, for all your design and conservation needs. And now, Optium® Museum Display Acrylic™ is available for display cases, vitrines and framed exhibits. Find out why museums around the world depend on Optium to protect, conserve and display their most valuable and historic collections. Optium. The Difference is Clear™.

To experience the clear difference, contact your authorized supplier for a free Optium Sample Kit or visit www.tru-vue.com/museums/grants.



Find Us:  

Tru Vue®, the Tru Vue logo, Optium®, Optium Acrylic® and Optium Museum Acrylic® are registered trademarks, and Optium® Museum Display Acrylic™ is a trademark of Tru Vue, Inc, McCook, IL USA. © 2009 Copyright Tru Vue, Inc. All rights reserved.

anti-reflective

anti-static

abrasion resistant

UV protection

American Institute
for Conservation of
Historic & Artistic Works

1156 15th Street, NW
Suite 320
Washington, D.C. 20005

info@conservation-us.org
www.conservation-us.org

AIC

American
Institute
of
Conservation
of
Historic
and
Artistic
Works

PERIODICAL

ART PRESERVATION SERVICES *New York City*

Look for our new products and website
this spring.

315 East 89th Street
New York, NY 10128
212-722-6300
www.apsnyc.com